

# >>>> Vertical Turning

## RAM Type Lathes



Superior Rigidity | Exceptional Precision

Series:

Ram Type Vertical with ATC

Ram Type Vertical Turn-mill with ATC

Ram Type Vertical Turn-mill with ATC & Continuous Feed for C axis



# Vertical Turning

## Ram-type Vertical Turning Lathes - Heavy-duty

VTL Series, Vertical ram-type lathes are introduced for heavy-duty jobs. Developed for large parts and multi-tasking operations. Conceptualized for single setup multi-tasking operations for bigger size jobs and without compromising on component quality and superior performance.

Built with Massive wide-column structure positioned on top of the one-piece bed, wide machining area, spindle with a rigid structure, Ram spindle and Flexibility options for power Configuration are the Innovative features for higher productivity.

Wide Range models, preferred choice for complex precision jobs of Automotive, Pumps, Valves and Railway segments for competitive manufacturing.

### Features listed below:

- Fixed Cross rail or Moving Cross rail options are available
- Monolithic base and column design, duly stress relieved and machined.
- The structure of the machine is designed after finite element analysis for achieving better rigidity and heavy cutting loads.
- Live spindle RAM
- Highly accurate C axes turning/milling tables
- Quick change tooling options ... many more

### Configuration

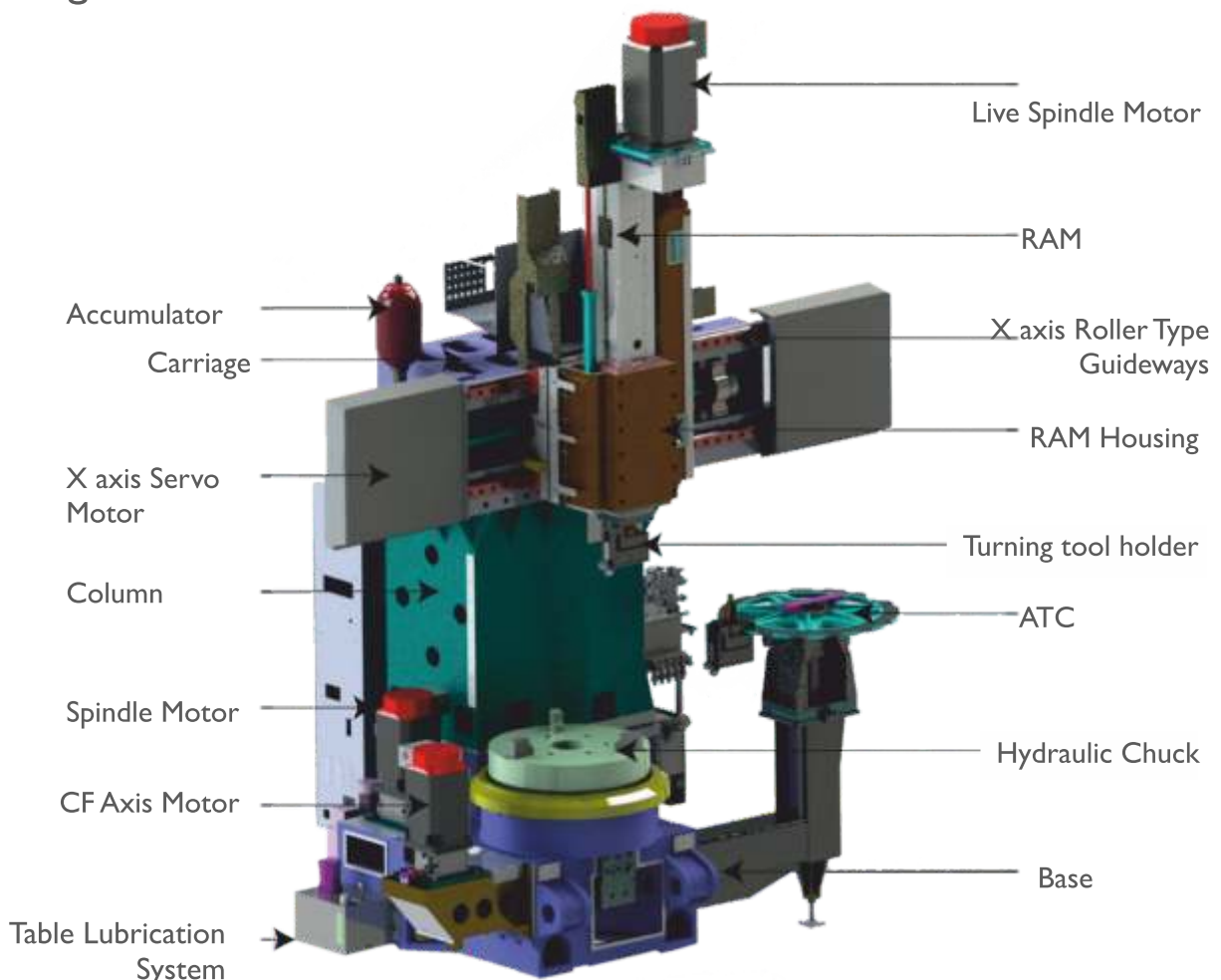

# >>>> Vertical Turning

Configuration - 800 RL/ 1000 RL

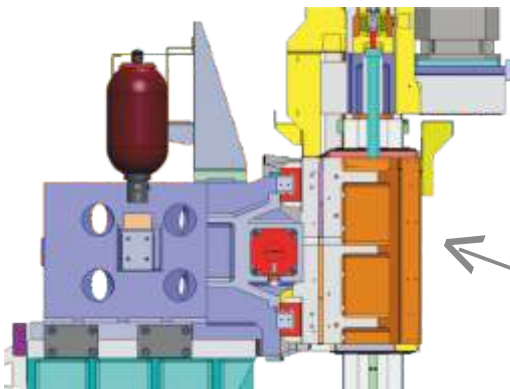

Roller type LM guide ways  
for X axis for high position accuracy

X axis Guideways close to RAM to  
reduce overhang

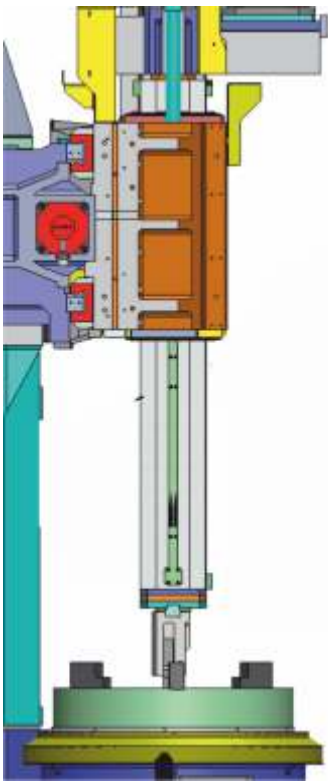

220 Square Ram Guided by Turcite slide  
Deep Boring Application upto 800 mm deep

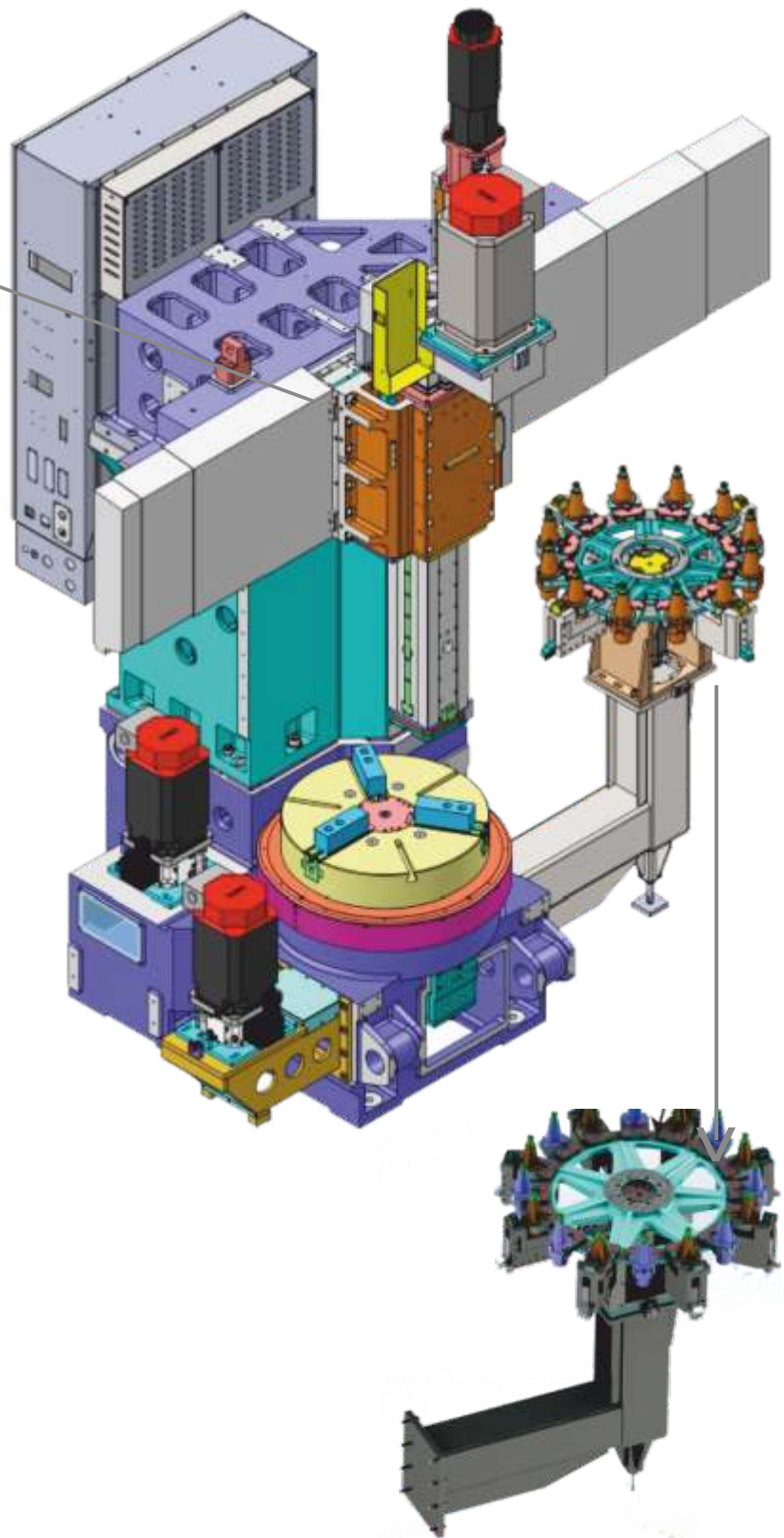

12 Tools Servo Drive ATC for Quick Indexing  
Side clamped to Base and supported on  
floor for 800 & 1000 size machines

# >>>> Vertical Turning

Configuration - I200 RL

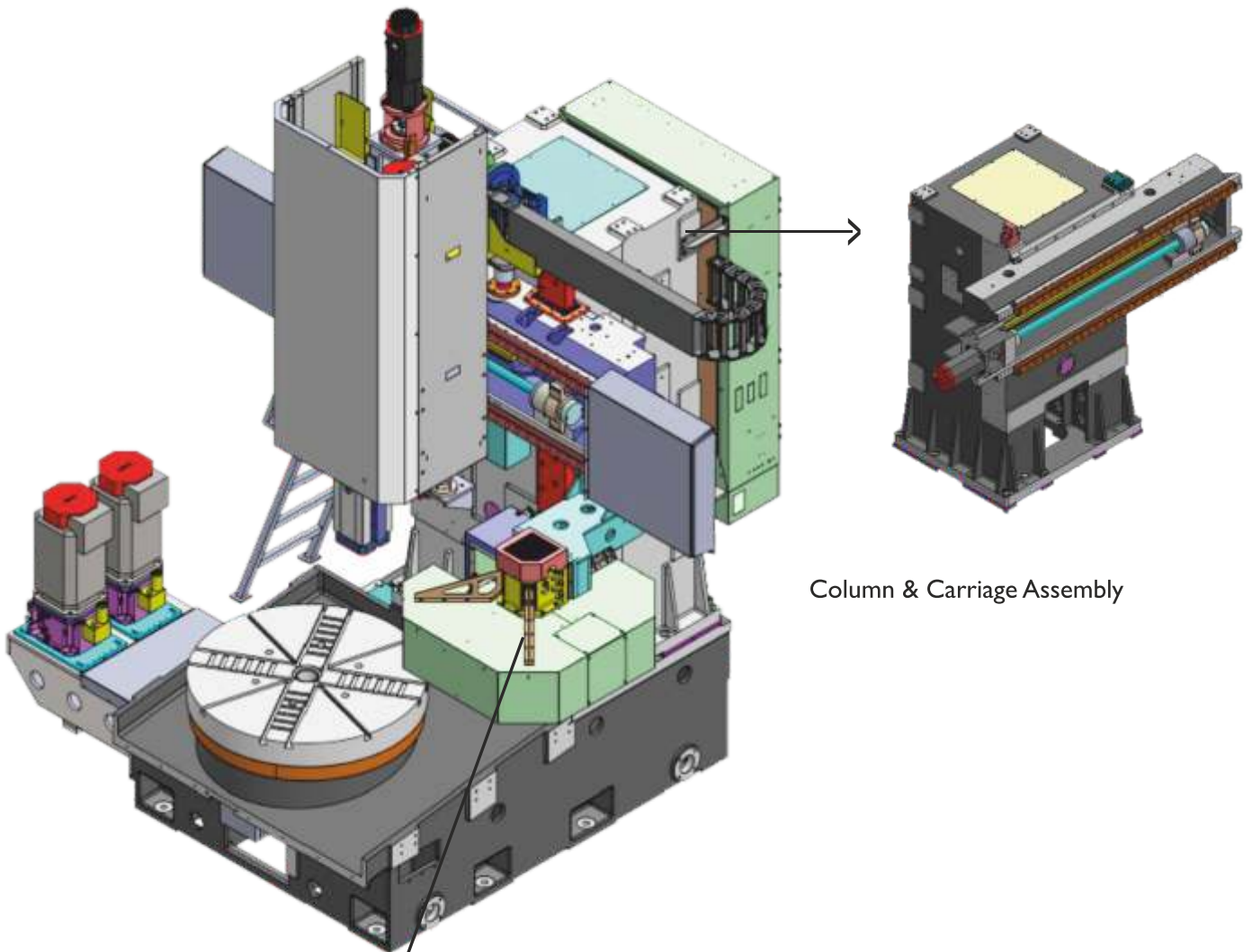

Column & Carriage Assembly



Carriage mounted ATC

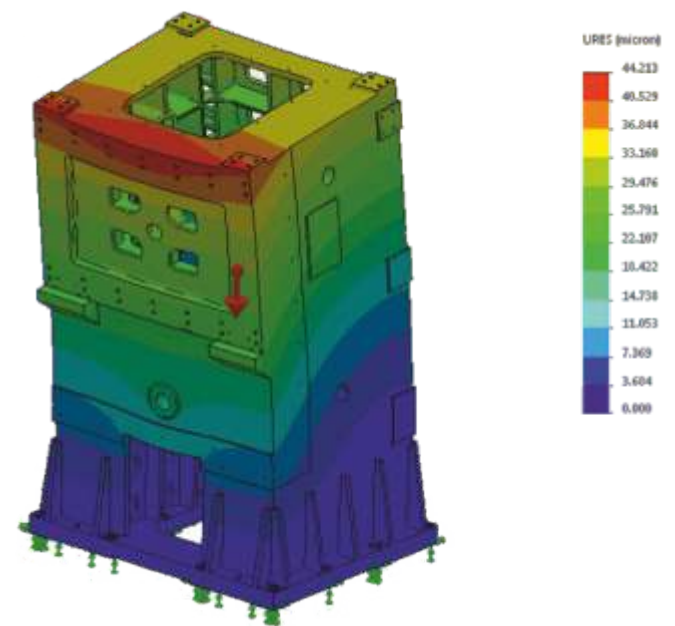

FEM Analysis

# Vertical Turning

## Spindle Characteristics

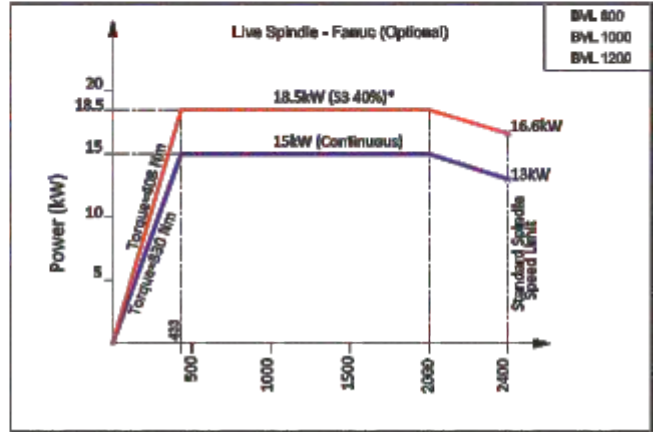
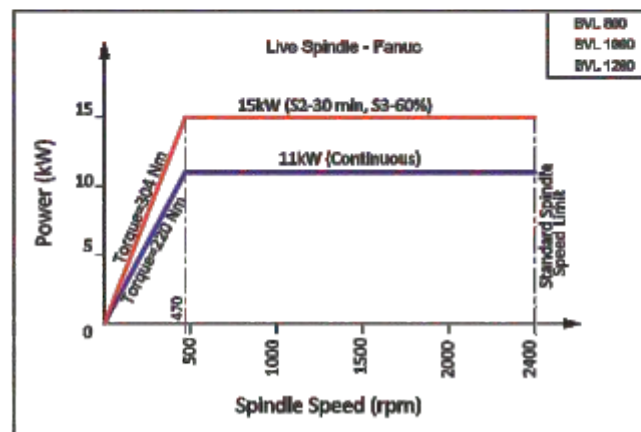
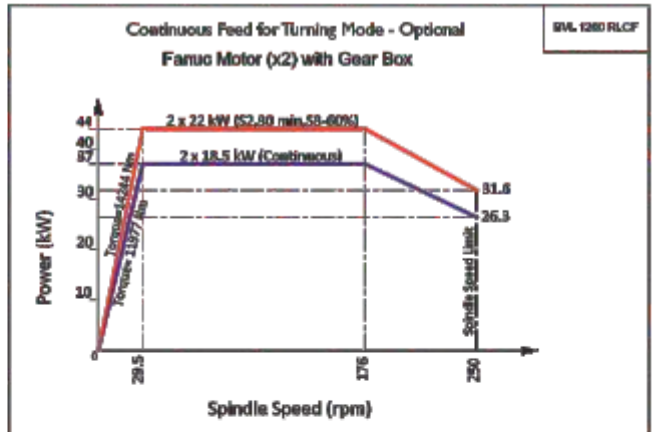
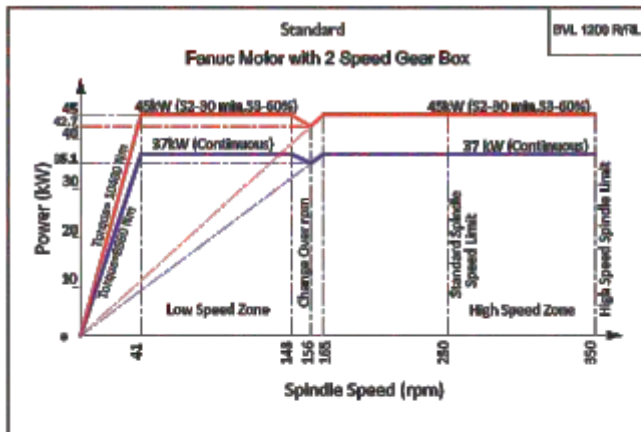
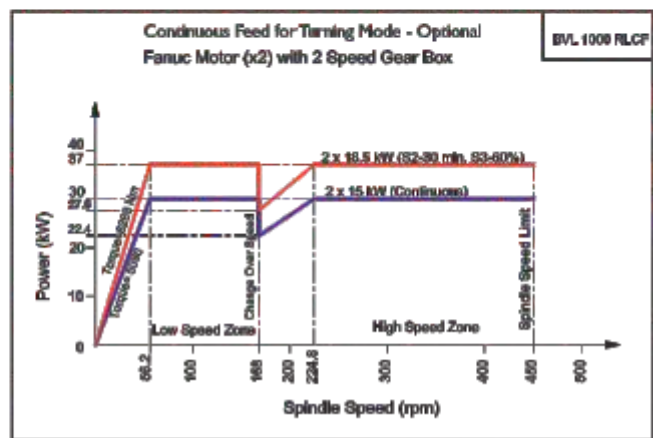
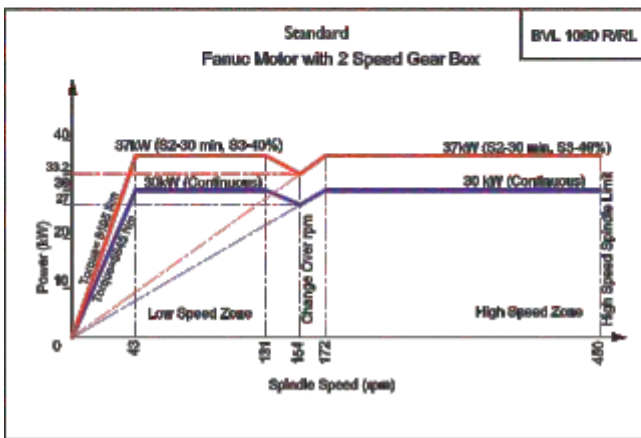
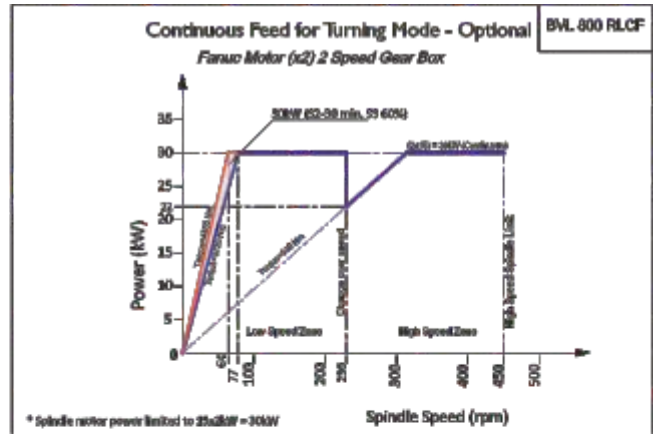
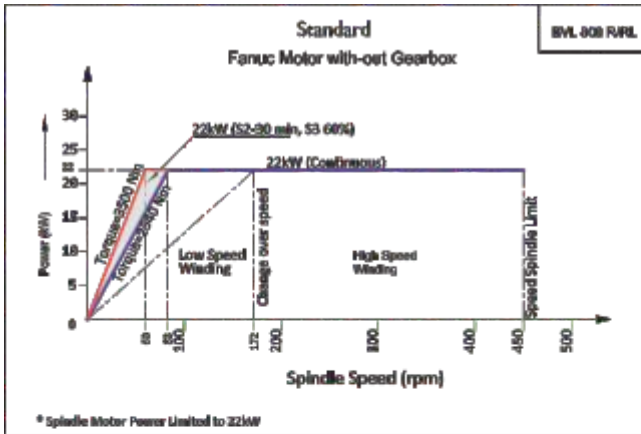

— S2 - 30 min / S3-40% / S3-60%. Intermittent Operating Zone  
— Continuous Operating Zone

# Vertical Turning

## X Axis Travel & ATC Tool Interference

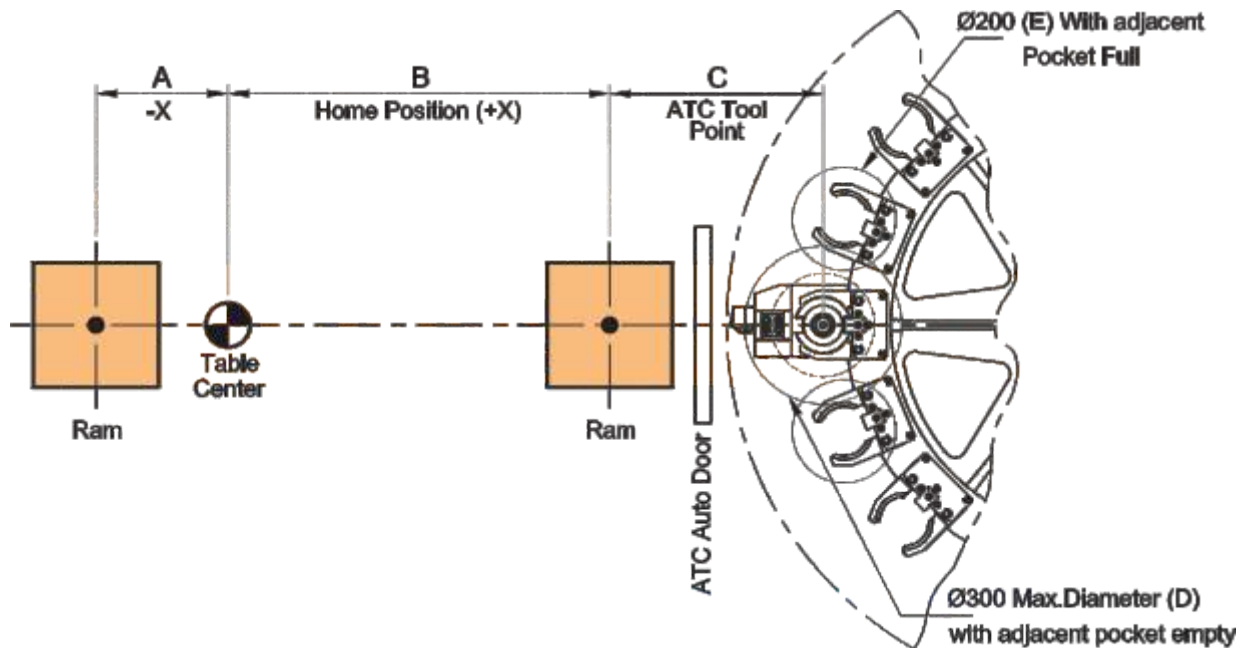

Model	A	B	C	D	E	No of Station			Avg Tool Weight	Max Tool Weight	Max Wt on ATC		
						Std	Optional				12STN	16STN	20STN
BVL 800 R	60	625	405	300	200	12	16	NA	30 kg*	50 kg*	360 kg	480 kg	NA
BVL 800 RL													
BVL 800 RL CF													
BVL 1000 R	60	720	405	300	200	12	16	NA	30 kg*	50 kg*	360 kg	480 kg	NA
BVL 1000 RL													
BVL 1000 RL CF													
BVL 1200 R	60	845	385	300	200	12	NA	20	30 kg*	50 kg*	360 kg	NA	600 Kg
BVL 1200 RL													
BVL 1200 RL CF													

\*Tools should be loaded on ATC uniformly.

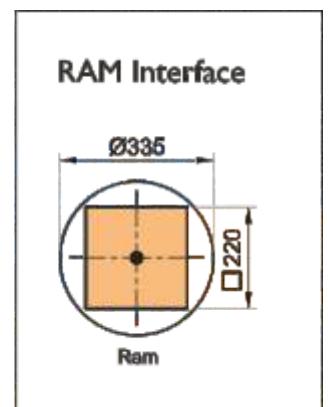
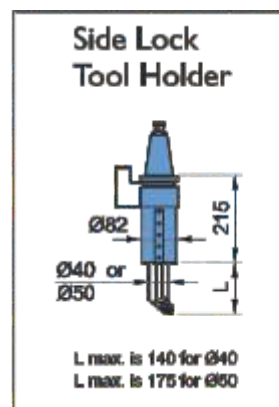
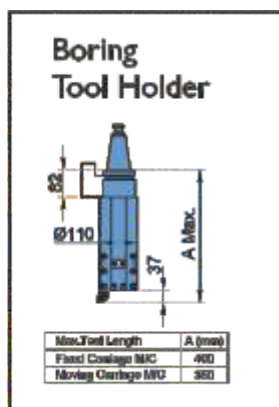
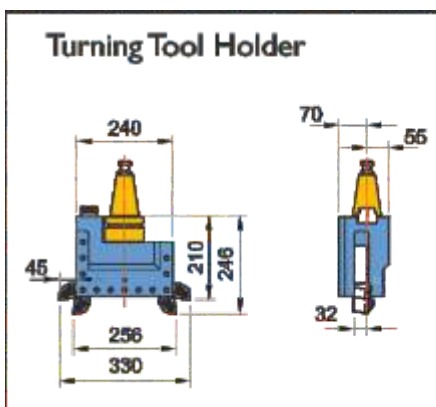

# Vertical Turning

## Moving Range Diagram - Moving Cross Rail

Model	A	B	C	D**	E	Z	G*	J	J1
BVL 1200 R									
BVL 1200 RL	1350	1250	335	1600	1200	825	800	1585	1475
BVL 1200 RL CF									

- \* Carriage moving option not available on BVL 800, BVL 1000 Ram machines.
- \*\* Max Height of swing diameter is applicable, when carriage is in top most position and other positions the max.height will change accordingly.  
- User to ensure max swing do not interfere with RAM during OD turning.
- \*\*\* Boring holder length is 350 mm. in this case, Max Component height will 1125 for face plate & 1015 mm for Hyd. Chuck
- \*\*\*\* Turning dia of 1350 mm at 1200 mm height is possible only when carriage is at top most position

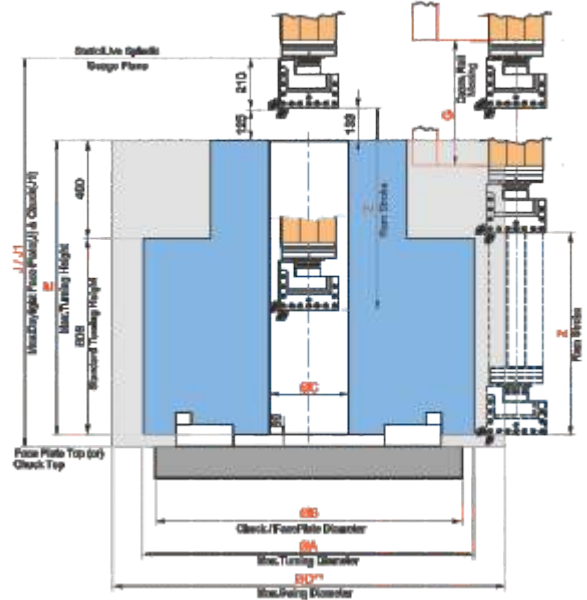

## Moving Range Diagram - For Fixed Cross Rail

					Face Plate		Chuck		G*	Z
	A	B	C	D	E	J	E1	J1		
BVL 800 R										
BVL 800 RL	900	800		1100	800	1055	800	1055	NA	
BVL 800 RL CF										
BVLR 1000 R										
BVL 1000 RL	1100	1000	335	1300	800	1055	760	1015	NA	825
BVL 1000 RL CF										
BVLR 1200 R										
BVL 1200 RL	1350	1250		1600	800	1055	750	1005	NA	
BVL 1200 RL CF										

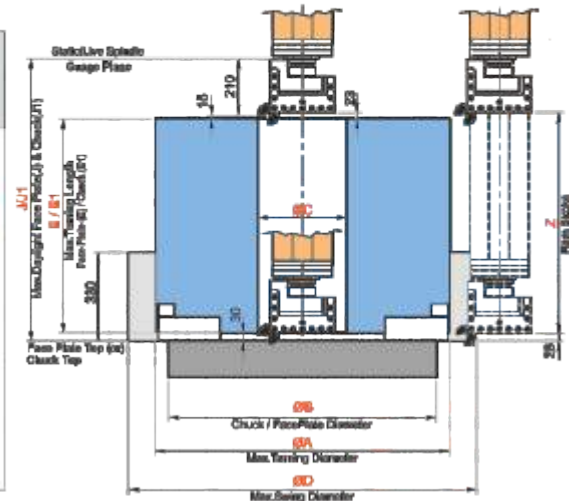

## Technical Specifications - Fixed Cross Rail

Specifications	Unit	BVL 800 R	BVL 800 RL	BVL 800 RL CF	BVL 1000 R	BVL 1000 RL	BVL 1000 RL CF	BVL 1200 R	BVL 1200 RL	BVL 1200 RL CF
Max Swing Diameter	mm	1100	1100	1100	1300	1300	1300	1600	1600	1600
Max Turning Dia	mm	900	900	900	1100	1100	1100	1350	1350	1350
Table diameter	mm	800	800	800	1000	1000	1000	1250	1250	1250
Maximum Job Envelope (Dia x length)	mm	900 x 800	900 x 800	900 x 800	1100 x 800	1100 x 800	1100 x 800	1350 x 800	1350 x 800	1350 x 800
Max weight on the spindle (Work holding + Job) Symmetric	kg	2000	2000	2000	4000	4000	4000	5000	5000	5000
Table Spindle										
Spindle Motor Power (SI) in Turning Mode	kW	22/ 22	22/ 22	2x15=30/ 30	30/ 37	30/ 37	2 x 15 = 30/ 37	37/ 45	37/ 45	2 x 18.5 = 37 / 44
Max Table Torque (SI/ 30 min) in Turning	Nm	2540/ 3500	2540/ 3500	3720/ 4580	6645/ 8195	6645/ 8195	5090/ 6280	8560/ 10400	8560/ 10400	11977/ 14244
Spindle speed range in turning Mode	rpm	10-450	10-450	10-450	10-450	10-450	10-450	10-250 (10-350)	10-250 (10-350)	10-250
Spindle motor power(SI) in CF Mode	kW	NA	NA	15	NA	NA	15	NA	NA	18.5
Spindle speed range in CF Mode	rpm	NA	NA	4	NA	NA	4	NA	NA	4
Live Tool Spindle - High Power										
Spindle Taper	type	NA	BT50	BT50	NA	BT50	BT50	NA	BT50	BT50
Speed Range	rpm	NA	50 to 2400	50 to 2400	NA	50 to 2400	50 to 2400	NA	50 to 2400	50 to 2400
Power (SI)	kW	NA	11 (15)	11 (15)	NA	11 (15)	11 (15)	NA	11 (15)	11 (15)
Torque (SI)	Nm	NA	220 (330)	220 (330)	NA	220 (330)	220 (330)	NA	220 (330)	220 (330)
X Axis										
Guide way	type	LM	LM	LM	LM	LM	LM	LM	LM	LM
Stroke (Horizontal travel)	mm	685 (-60 to + 625)	685 (-60 to + 625)	685 (-60 to + 625)	780 (-60 to + 720)	780 (-60 to + 720)	780 (-60 to + 720)	905 (-60 to + 845)	905 (-60 to + 845)	905 (-60 to + 845)
Rapid traverse rate (Max)	m/ min	15	15	15	15	15	15	15	15	15
Z Axis										
Guide ways	type	Box type Hardened	Box type Hardened	Box type Hardened	Box type Hardened	Box type Hardened	Box type Hardened	Box type Hardened	Box type Hardened	Box type Hardened
Stroke (Vertical travel of RAM)	mm	825	825	825	825	825	825	825	825	825
Rapid traverse rate (Max)	m/ min	10	10	10	10	10	10	10	10	10
RAM cross section	mm	220 x 220	220 x 220	220 x 220	220 x 220	220 x 220	220 x 220	220 x 220	220 x 220	220 x 220
Automatic Tool Changer										
Tool Taper	type	BT50	BT50	BT50	BT50	BT50	BT50	BT50	BT50	BT50
No of Tool Position - Umbrella Type	No	12 (16)	12 (16)	12 (16)	12 (16)	12 (16)	12 (16)	12 (20)	12 (20)	12 (20)
Average Tool Weight	kg	30	30	30	30	30	30	30	30	30
Max Tool Weight	kg	50	50	50	50	50	50	50	50	50
Max Tool Weight on ATC Disc	kg	360 (480)	360 (480)	360 (480)	360 (480)	360 (480)	360 (480)	360 (600)	360 (600)	360 (600)
Max Tool Holder Size on ATC	mm	240 W x 125 T x 350 H	240 W x 125 T x 350 H	240 W x 125 T x 350 H	240 W x 125 T x 350 H	240 W x 125 T x 350 H	240 W x 125 T x 350 H	240 W x 125 T x 350 H	240 W x 125 T x 350 H	240 W x 125 T x 350 H
Turning Tool Size	mm	32 x 32	32 x 32	32 x 32	32 x 32	32 x 32	32 x 32	32 x 32	32 x 32	32 x 32
Boring Tool Size	mm	25 x 25	25 x 25	25 x 25	25 x 25	25 x 25	25 x 25	25 x 25	25 x 25	25 x 25
Accuracies as ISO 230-2										
Positioning accuracy	mm	0.02	0.02	0.02	0.02	0.02	0.02	0.02	0.02	0.02
Positioning repeatability	mm	0.015	0.015	0.015	0.015	0.015	0.015	0.015	0.015	0.015
Positioning accuracy of C-Axis	Arc-sec	NA	+/- 36	+/- 12	NA	+/- 36	+/- 12	NA	+/- 36	+/- 12
Tank Capacity										
Hydraulic tank	Ltr	50	50	50	50	50	50	50	50	50
Coolant tank	Ltr	600	600	600	800	800	800	800	800	800
Lubrication tank for slides	Ltr	5	5	5	5	5	5	5	5	5
Lubrication tank for table bearings	Ltr	90	90	90	90	90	90	90	90	90
Lubrication tank for CF gearboxes	Ltr	NA	NA	40	NA	NA	40	NA	NA	40
Miscellaneous										
CNC System	make	Fanuc	Fanuc	Fanuc	Fanuc	Fanuc	Fanuc	Fanuc	Fanuc	Fanuc
Machine dimensions (With Chip Conveyor & Coolant system)	mm	Ref DWG	Ref DWG	Ref DWG	Ref DWG	Ref DWG	Ref DWG	Ref DWG	Ref DWG	Ref DWG
Power requirement	kVA	50	50	65	65	65	65	75	90	90
Machine weight (Apx.)	kg	13000	13000	13000	18000	18000	18000	24000	24000	24000

( ) are optional



# Technical Specifications - Moving Cross Rail

Specifications	Unit	BVL 1200 R	BVL 1200 RL	BVL 1200 RL CF
Max Swing Diameter	mm	1600	1600	1600
Max Turning Dia	mm	1350	1350	1350
Max Turning Height with repositioning carriage	mm	1200	1200	1200
Table diameter	mm	1250 (1500)	1250 (1500)	1250 (1500)
Maximum Job Envelope (Dia x length)	mm	1350 x 1200	1350 x 1200	1350 x 1200
Max weight on the spindle (Work holding + Job) Symmetric	kg	5000	5000	5000
<b>Table Spindle</b>				
Spindle Motor Power (SI) in Turning Mode	kW	37/ 45	37/ 45	2 x 18.5 = 37 / 45
Max Table Torque (SI/ 30 min) in Turning	Nm	8560/ 10400	8560/ 10400	11977/ 14244
Spindle speed range in turning Mode	rpm	10-250 (10-350)	10-250 (10-350)	10-250
Spindle motor power(SI) in CF Mode	kW	NA	NA	18.5
Spindle speed range in CF Mode	rpm	NA	NA	4
<b>Live Tool Spindle - High Power</b>				
Spindle Taper	type	NA	BT50	BT50
Speed Range	rpm	NA	50 to 2400	50 to 2400
Power (SI)	kW	NA	11 (15)	11 (15)
Torque (SI)	Nm	NA	220 (330)	220 (330)
<b>X Axis</b>				
Guide way	type	LM	LM	LM
Stroke (Horizontal travel)	mm	905 (-60 to + 845)	905 (-60 to + 845)	905 (-60 to + 845)
Rapid traverse rate (Max)	m/ min	15	15	15
<b>Z Axis</b>				
Guide ways	type	Box type Hardened	Box type Hardened	Box type Hardened
Stroke (Vertical travel of RAM)	mm	825	825	825
Rapid traverse rate (Max)	m/ min	10	10	10
RAM cross section	mm	220 x 220	220 x 220	220 x 220
<b>ZI Axis</b>				
Vertical travel of cross rail ( in steps of 200 mm-5 Positions)	mm	800	800	800
Max turning diameter	mm	1350	1350	1350
Max turning height (by Manual repositioning of ZI)	mm	1200	1200	1200
Maximum boring length	mm	800	800	800
Rapid rate	mm/ min	350	350	350
Positioning & Clamping Cylinder	-	for heavy cutting	for heavy cutting	for heavy cutting
<b>Automatic Tool Changer</b>				
Tool Taper	type	BT50	BT50	BT50
No of Tool Position - Umbrella Type	No	12 (20)	12 (20)	12 (20)
Average Tool Weight	kg	30	30	30
Max Tool Weight	kg	50	50	50
Max Tool Weight on ATC Disc	kg	360 (600)	360 (600)	360 (600)
Max Tool Holder Size on ATC	mm	240 W x 125 T x 350 H	240 W x 125 T x 350 H	240 W x 125 T x 350 H
Turning Tool Size	mm	32 x 32	32 x 32	32 x 32
Boring Tool Size	mm	25 x 25	25 x 25	25 x 25
<b>Accuracies as ISO 230-2</b>				
Positioning accuracy	mm	0.02	0.02	0.02
Positioning repeatability	mm	0.015	0.015	0.015
Positioning accuracy of C-Axis	Arc-sec	NA	+/- 36	+/- 12
<b>Tank Capacity</b>				
Hydraulic tank	Ltr	50	50	50
Coolant tank	Ltr	800	800	800
Lubrication tank for slides	Ltr	5	5	5
Lubrication tank for table bearings	Ltr	90	90	90
Lubrication tank for CF gearboxes	Ltr	NA	NA	40
<b>Miscellaneous</b>				
CNC System	make	Fanuc	Fanuc	Fanuc
Power requirement	kVA	75	90	90
Machine weight (Apx.)	kg	24000	24000	24000

\* Data in Brackets are in optional

# Vertical Turning

## CNC Features

System Features	FANUC Oi TF Plus	Siemens 828D	Mitsubishi
Display & Keyboard	10.4 inches colour LCD	10.4 inches colour LCD	10.4 inches colour LCD
Maximum feed axes	5	5	5
Simultaneously controllable axis	4	4	4
Minimum input increment	0.001 mm, 0.001 deg	0.001 mm, 0.001 deg	0.001 mm, 0.001 deg
Spindle speed function	4-digit S code	4-digit S code	4-digit S code
Spindle speed override	50 % - 120 % (in steps of 10 %)		
Feed override	200 % (in steps of 10 %) 0-120 % with Siemens		
Feed rate command	4-digit F code	4-digit F code	4-digit F code
Inch- mm conversion	YES	YES	YES
Part program storage length	2 MB	3 MB	500 KB
Number of part programs	1000	750	1000
Sub program call	10 Levels	11 Levels	10 Levels
Number of tool offsets	128	160 ( 256 with 26 X, 512 with 28 X)	200
Program number/ sequence number search	YES	Search with "text" is STD, with line, block number, interrupt etc is option	YES
Single block	YES	YES	YES
Optional stop	YES	YES	YES
Dry run	YES	YES	YES
PCMCIA memory card	O	Option with CF card	S with SD card
DNC operations	YES with PCMCIA card	YES with CF card	YES with SD card
Run hour & part count	YES	YES	YES
Online Help function	YES	YES	YES
Graphic display	YES	YES	YES
Embedded Ethernet	YES	S for diagnosis & service (Option for part program execution / DNC)	YES
Front USB interface	YES	YES	YES
Fast Ethernet Data Server	O	O	YES
Remote diagnosis	YES	YES	YES
High speed skip (Probe function)	O	O	YES
Dynamic graphic display	O	O	YES
Animated Cycle support	Option with manual Guide Oi	ISO program guide.	ISO/ Navi lathe
3D Simulation & Real time simulation	Option (Dynamic Graphics)	O	YES
Machine Maintenance planner	Yes (Periodic maintenance)	YES	YES (Custom Screen)
2D simulation	YES	YES	YES
Tool life Monitoring	YES	Yes (Time and Count) Sister tool/ Tool grouping is option	YES
Energy Monitoring system	YES	Yes - Control Energy	YES
Operation history function	YES	Alarm History	YES
Trouble shooting guidance function	YES	YES	YES
8 level data protection with password	YES ( 4 level standard, 8 level option)	YES (Lower 4 level by PLC, Upper 3 by password)	YES, 8 levels standard
Min block cycle time	0.9 milliseconds	6/ 3 milliseconds	0.6 milliseconds
Max no of tools cutting edges	128	128/ 256	400
Max no of settable zero offsets	6	50	54

## CNC FUNCTIONS

Linear Interpolation	YES
Circular Interpolation	YES
Cylindrical Interpolation	YES
Absolute / Increment programing	YES
Canned cycle	YES
Work Piece coordinate system	YES
Background editing	YES
Backlash Compensation	YES

Polar co-ordinate	YES
Rigid Tapping	YES
Rigid Tapping Retraction	O
Look ahead function	O
Program Number Search	YES
Sequence Number Search	YES
Program Restart / Block Search	YES
Helical Interpolation (RLCF Machine)	O

Tandem Control	O
Manual Guide Oi	O
Manual Guide i	O
Thread Milling (RLCF Machine)	O
Drilling	YES
Threading	YES
Milling	YES

# Vertical Turning

## Advanced Dual Drive Technology (RLCF Feature)

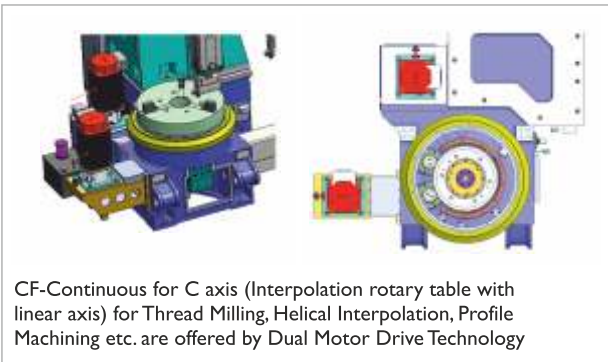

CF-Continuous for C axis (Interpolation rotary table with linear axis) for Thread Milling, Helical Interpolation, Profile Machining etc. are offered by Dual Motor Drive Technology

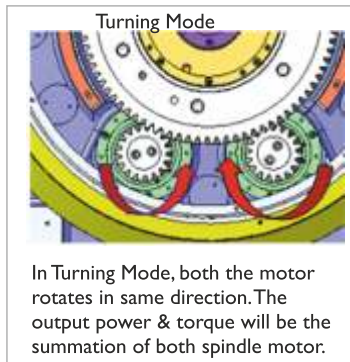

In Turning Mode, both the motor rotates in same direction. The output power & torque will be the summation of both spindle motor.

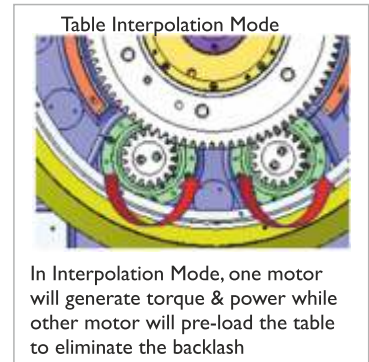

In Interpolation Mode, one motor will generate torque & power while other motor will pre-load the table to eliminate the backlash

## Advantages

- Accurate electronic pre-load system
- More reliable by reduced mechanical parts & simple mechanism
- Better efficiency of output power & torque when compared to worm shaft & worm wheel drive system for CF axis
- Minimum wear & tear since hardened and grounded pinion & bull gear are the only mechanical parts for CF axis
- Quick and easy method to vary pre-load for elimination of backlash
- Better accuracy on profile (less wear & tear and their-by less backlash)

## Applications



Butterfly Valve



Diffuser



Clutch Plate



Die



Globe Valve



Case

Many more...

# Vertical Turning

## Standard & Optional Features

Description	BVL 800 R	BVL 800 RL	BVL 800 RLCF	BVL 1000 R	BVL 1000 RL	BVL 1000 RLCF	BVL 1200 R	BVL 1200 RL	BVL1200 RLCF
Rigid Cast structure for machine base, Column, Carriage and RAM Housing	S	S	S	S	S	S	S	S	S
CNC System - Fanuc OiTF+ with 10.4" Colour Monitor	S	S	S	S	S	S	S	S	S
Heavy Duty LM Guide-ways on X Axis and Box Guide ways on Z axis	S	S	S	S	S	S	S	S	S
Directly coupled Axis Motors	S	S	S	S	S	S	S	S	S
220 Square RAM	S	S	S	S	S	S	S	S	S
Live Spindle on BT50 Taper for tool clamping	NA	S	S	NA	S	S	NA	S	S
C axis for Accurate Indexing	NA	S	S	NA	S	S	NA	S	S
Heavy duty umbrella type Tool magazine with 12 tools	S	S	S	S	S	S	S	S	S
Face plate with 4 jaws independently opera-table box Jow assembly	S (Dia 800)	S (Dia 800)	S (Dia 800)	S (Dia 1000)	S (Dia 1000)	S (Dia 1000)	S (Dia 1250)	S (Dia 1250)	S (Dia 1250)
I set of Static tool holders (I TH + I BTH+ I SLH)	S	S	S	S	S	S	S	S	S
Hydraulic counter balance for RAM	S	S	S	S	S	S	S	S	S
Hydraulic Power pack with Float level switch	S	S	S	S	S	S	S	S	S
Automatic Centralized Oil Lubrication System	S	S	S	S	S	S	S	S	S
Std. Cooling system for Cutting and bed flushing	S	S	S	S	S	S	S	S	S
Chip Conveyor with Chip Bin	S	S	S	S	S	S	S	S	S
Slat type for Steel	S	S	S	S	S	S	S	S	S
Totally enclosed machine Guard	S	S	S	S	S	S	S	S	S
AC Unit for Electrical Cabinet (Panel Mounted type)	S	S	S	S	S	S	S	S	S
Machine Lamp & 3 tier lamp	S	S	S	S	S	S	S	S	S
Safety Door Interlock (Limit switch type)	S	S	S	S	S	S	S	S	S
Electronic hand wheel (MPG)	S	S	S	S	S	S	S	S	S
Air & Coolant Gun	S	S	S	S	S	S	S	S	S
Oil Skimmer	S	S	S	S	S	S	S	S	S
Two-speed Gearbox	NA	NA	S	NA	NA	S	NA	NA	S
Continues feed for C Axis	NA	NA	S	NA	NA	S	NA	NA	S
<b>Essential Accessories</b>									
Voltage Stabilizer	O	O	O	O	O	O	O	O	O
Chip Conveyor with Chip Bin (Scraper type for Cast IRON)	O	O	O	O	O	O	O	O	O
<b>Optional Accessories</b>									
Hydraulically operated self centering Chuck - 3 Jaw	Option - dia 800 Chuck			Option - dia 1000 Chuck			Option - dia 1250 Chuck		
Jaw Box Assembly mountable on chuck - 4 Jaw	Option with dia 800 Chuck			Option with dia 1000 Chuck			Option with dia 1250 Chuck		
Cross Rail Movement - 800 mm stroke (in steps of 200)	NA	NA	NA	NA	NA	NA	O	O	O
High speed table spindle	NA	NA	NA	NA	NA	NA	10 to 350 RPM is option		
High Column to increase Day light - 220 mm (No Extra Z/ ZI stroke)	NA	NA	NA	O	O	O	O	O	O
ATC with 16 tools	O			O			NA		
ATC with 20 tools	NA	NA	NA	NA	NA	NA	O	O	O
Coolant through Spindle (Pump capacity 20 LPM and 16 bar pressure) Hydro cyclone	NA	O	O	NA	O	O	NA	O	O
Coolant through Spindle (Pump capacity 20 LPM and 16 bar pressure) Compact Paper Band & Magnetic coolant filtration system	NA	O	O	NA	O	O	NA	O	O
Linear scale for X axis	O	O	O	O	O	O	O	O	O
Linear scale for X and Z axis	O	O	O	O	O	O	O	O	O
Work piece Measuring probe	O	O	O	O	O	O	O	O	O
Right angle head*	NA	*	*	NA	*	*	NA	*	*
High / low dual clamping circuit for hydraulic chuck	Option with Dia 800			Option with Dia 1000			Option with Dia 1250		
Additional Turning tool holder with BT 50 for turning	O	O	O	O	O	O	O	O	O
Additional Boring tool holder with BT 50 taper for boring	O	O	O	O	O	O	O	O	O
Dia 40, 50 Additional Side lock holder with BT50 taper for	O	O	O	O	O	O	O	O	O
Extra set of Soft Jaws	Option with Dia 800 Chuck			Option with Dia 1000 Chuck			Option with Dia 1250 Chuck		
Siemens CNC system*	O	O	O	O	O	O	O	O	O

\* Available on Request

# Vertical Turning

## Work Holding Systems

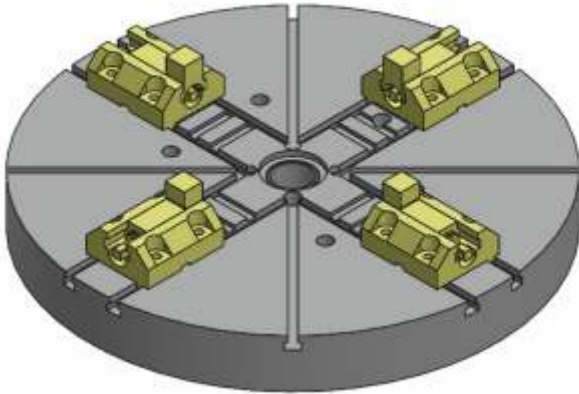

Face Plate with Jaw Box Assembly

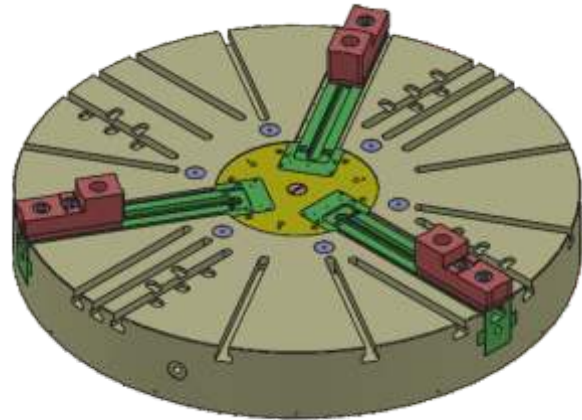

3 Jaw Hydraulic Chuck with provision to mount 4 Nos. Jaw box assembly

## Machine Dimensions

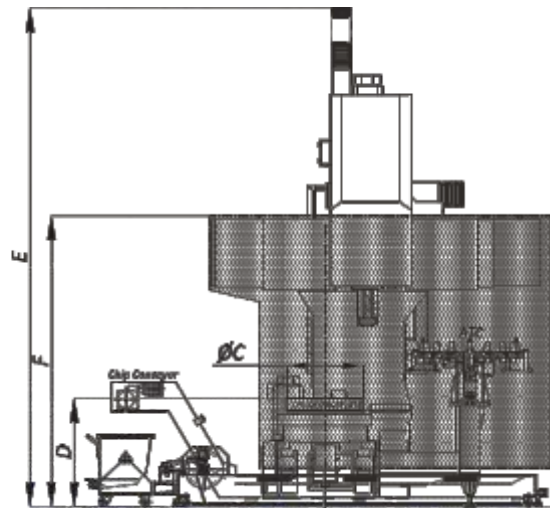
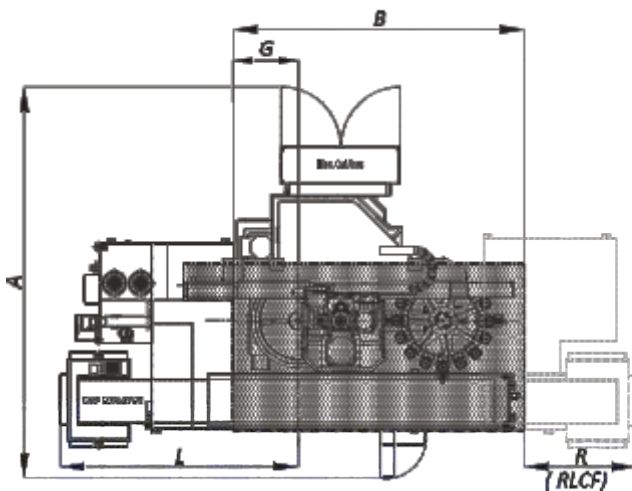

Model	A	L	B	øC	D	E	F	R	G
BVL 800 R/ RL	4400	2500	3160	800	1135	5180	3200	-	685
BVL 800 RL CF	4400	-	3160	800	1135	5180	3200	1172	685

# Vertical Turning

## Machine Dimensions

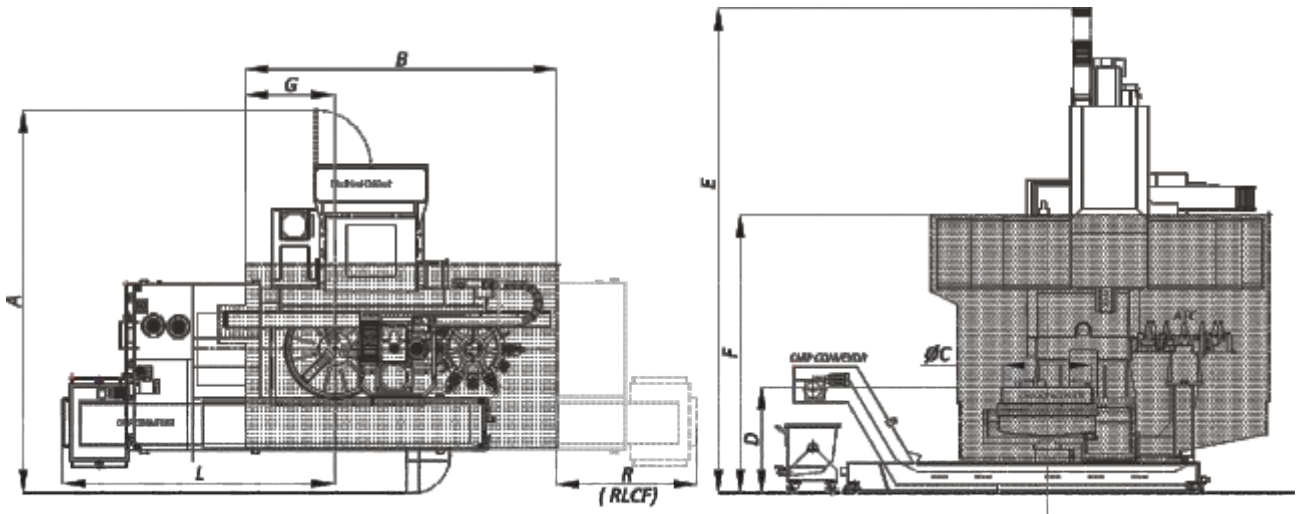

Model	A	L	B	ØC	D	E	F	R	G
BVL 1000 R/ RL	4500	3050	3555	1000	1175	1215	5180	-	1000
BVL 1000 RL CF	4500	-	3555	1000	1175	1215	5180	1840	1000

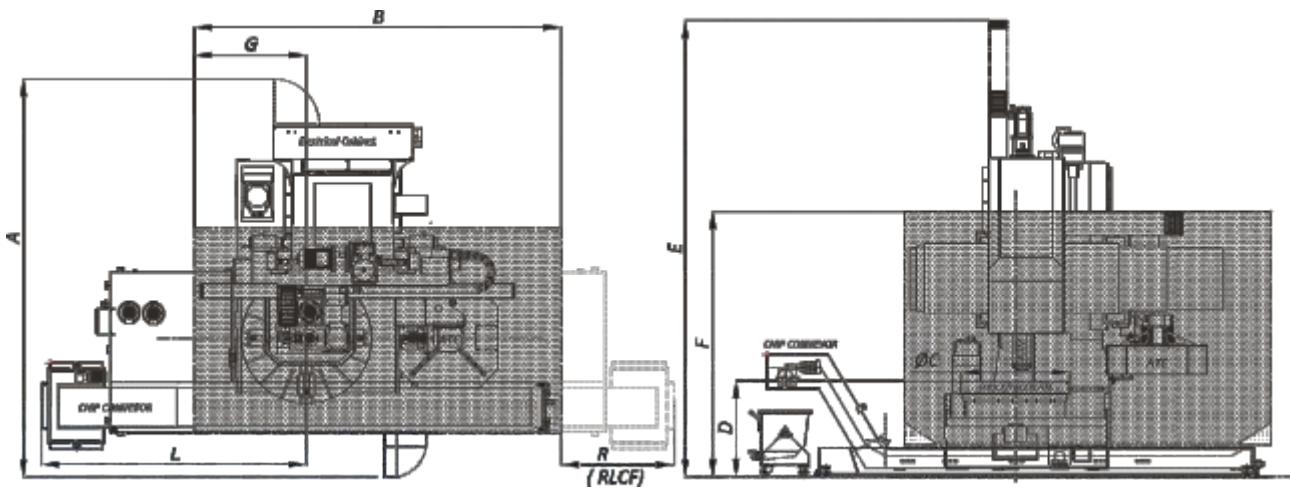

Model	A	L	B	ØC	D	E	F	R	G
BVL 1200 R/ RL	4800	3050	4320	1250	1216	1266	5500	-	1290
BVL 1200 RL CF	4800	-	4320	1250	1216	1266	5500	1322	1290

# Network

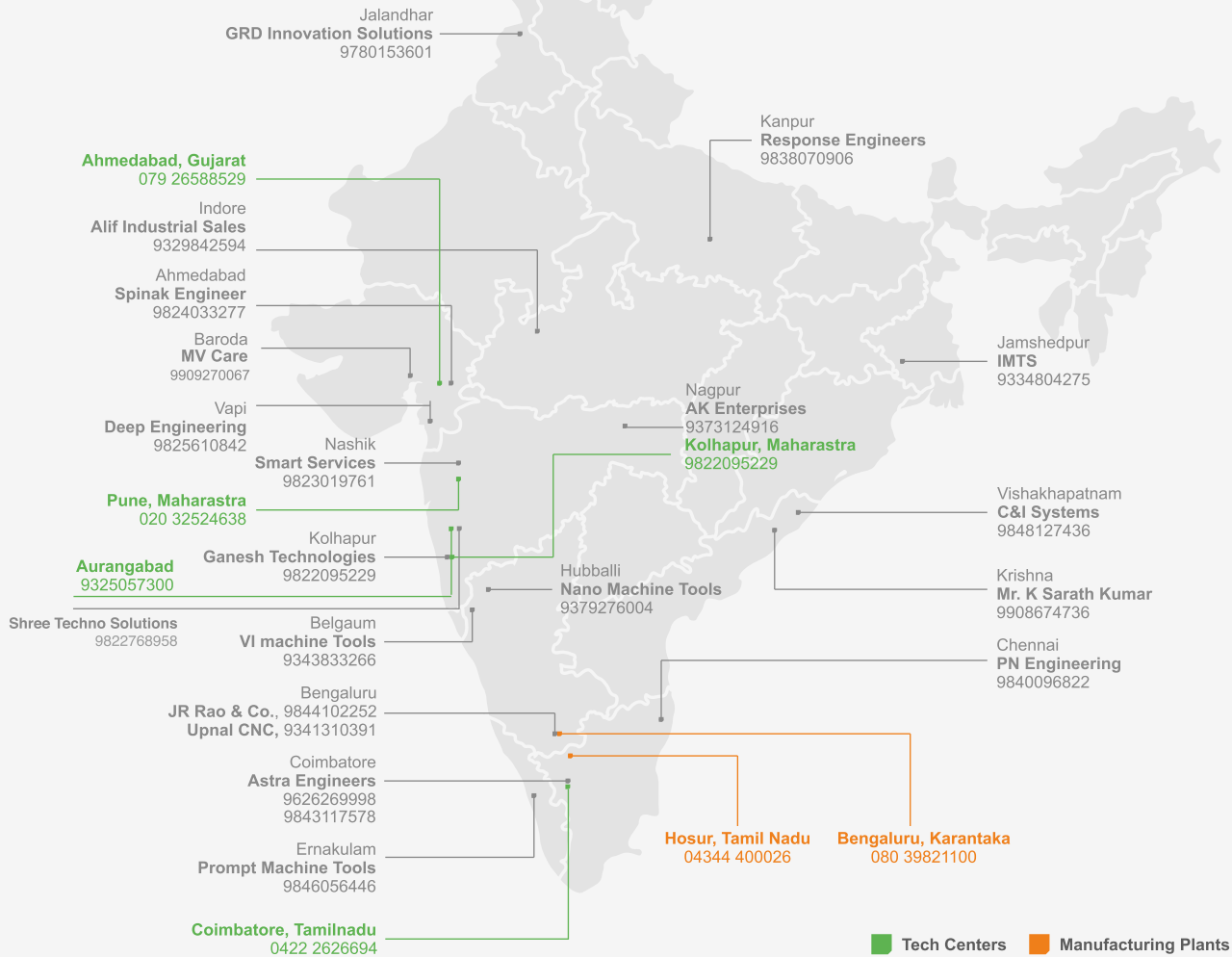

## International Network

- Bangladesh • Bahrain • China • France • Germany • Iran • Kuwait • Netherlands • Oman • Poland
- Qatar • Russia • Saudi Arabia • Sri Lanka • South Africa • Thailand • Turkey • UAE



**Bharat Fritz Werner**  
 Off Tumkur Road, Bangalore 560022, India  
 Ph: 080-39821100 | e-mail: [bfwmarketing@bfw.co.in](mailto:bfwmarketing@bfw.co.in) | URL: [www.bfwindia.com](http://www.bfwindia.com);

Belgaum	Block 4, Plot 737, Khanapur Road, Near Railway Gate 3, Udyambag, Belgaum 590008.
Chennai	D22, First Floor, First Street, Sector 3, Ambattur Industrial Estate (South), Chennai - 600058. Ph: (044)26251505. E-mail: <a href="mailto:bfwchennai@bfw.co.in">bfwchennai@bfw.co.in</a>
Coimbatore	7, Karayampalayam Road, Mylapatti (PO) Coimbatore - 641 062. Ph (0422) 2626694, E-mail: <a href="mailto:bfwcoimbatore@bfw.co.in">bfwcoimbatore@bfw.co.in</a>
Gurgaon	Spaze tech park; office no 769, 7th floor, tower B2, Sector 49, Sohna road, Gurgaon 0- 122018
Hyderabad	Flat No 204, 1-11-229, Ramaveda Srisampada Apt. Near Shyamalaj Bldgs, Begumpet, Hyderabad - 500016, Ph: (040) 27762035, E-mail: <a href="mailto:bfwhyderabad@bfw.co.in">bfwhyderabad@bfw.co.in</a>
Kolkata	D - 4/ 4, Gillander House, 8, Netaji Subhash Road, Kolkata 700001. Ph (033) 40102140 - 42, 22623387, Fax (033) 4005691, E-mail: <a href="mailto:bfwkolkata@bfw.co.in">bfwkolkata@bfw.co.in</a>
Mumbai	206, Runwal Commercial Complex, LBS Marg, Mulund West, Mumbai 400080. Ph: (022) 25653362/ 58. Fax: (033) 40056911. E-mail: <a href="mailto:bfwmumbai@bfw.co.in">bfwmumbai@bfw.co.in</a>
New Delhi	510, Mahatta Towers, B - Block, Community Center, Janakpuri, New Delhi 110058. Ph: (011) 25522210. Fax: (011) 4 5629699. E-mail: <a href="mailto:bfwdelhi@bfw.co.in">bfwdelhi@bfw.co.in</a>
Pune	BFW House, 124 A, H block, MIDC, Pimpri, Pune 411018. Ph: (020) 32524638. E-mail: <a href="mailto:bfwpune@bfw.co.in">bfwpune@bfw.co.in</a>
Pune Chakan MIDC	No.3, Vedant Plaza, Plot No. PAP 40&41, Phase 1, Chakan MIDC, Near Suzlon Generators Ltd. Pune - 410501
Punjab	Suite No 205, 2nd floor, E-195, Industrial Area, Phase - VIII B, S A S Nagar, Mohali (Punjab) - 160071
Rajkot	85-86, 4th Floor, Samrudhhi Bhavan, Opp. Bombay Garage petrol pump, Gondal Road, Rajkot 360002. E-mail: <a href="mailto:bfwrajkot@bfw.co.in">bfwrajkot@bfw.co.in</a>

Representatives at Jamshedpur(Jharkhand) - 938030800, Kolhapur (Maharashtra)- 9370958107, Hosur (Tamilnadu) 9342336169

We are continuously working on the development of our products, the information contained in this brochure is subject to modification. While all efforts have been made to ensure that this publication carries the correct information, the reader is advised to consult an authorised representative of Bharat Fritz Werner to ascertain latest details.

kankal@BFWVT\_Ramhyar\_20-10-23